



3D FURLER INSTALLATION GUIDE

Welcome

This guide walks you through installing the 3D Furler system with clear steps, helpful tips, and easy-to-follow diagrams. Whether you're upgrading or setting up for the first time, it's designed to make the process smooth, safe, and stress-free.

3DFurler
help@3dfurler.com
904-600-4105
Version 6

Contents



.....	2
3D Furler™ Installation Manual	2
Introduction	2
Parts Included	2
Tools and Materials Required	2
Preparation for Installation	3
Step 1 Drum Assembly.....	4
Step 2 Top Assembly.....	5
Step 3 Install Foils , Luff Feed and Insert into Drum.....	6
Step 4 Final Check	8
Step 5 Add the Sail and Trim Halyard Lines.....	9
Step 6 Trial the System.....	10
Operating the 3D Furler System.....	11
Trouble Shooting.....	13



3D Furler™ Installation Manual

By 3DFURLER.COM Email: Help@3DFURLER.COM Tel. 904-600-4105

Introduction

Congratulations on your 3D Furler Purchase. The 3D Furler is designed for lasting performance and simple operation, featuring a design without bearings or halyard wrap risks. It installs in minutes and fits any sailboat.

Parts Included

- Top Assembly Parts A & B
- First Foils B (Marked AFFB & AFFA (1 of each)
- Foil Profiles (A & B)
- Insert Lock Pins (100)
- Pulleys (2)
- 8 Drum Bolt Spacers
- Drum Halves (2) & Alignment Insert Pins (2 + 2 spares)
- 4 ¼ - 20 x 1.5 Inch Round Head Stainless Steel Bolts and Nylon Nuts). (DRUM)
 - 2 - 8/32 Stainless Steel Pad Eyes, Nuts and Bolts for Drum Top
 - 2 ¼ - 20 x 1 Inch Stainless Steel Bolts and Nylon Nuts for Lower Half of Top Assembly
 - 2 ¼ - 20 x 2 Inch Stainless Steel Bolts and Nylon Nuts for Top Half of Top Assembly.



Tools and Materials Required

- Philips Screwdriver to fit ¼ - 20 bolts and 8/32.
- Adjustable Wrench
- Nut Driver ¼ Inch to fit ¼ - 20 Nylon Nuts and 11/32 for the #8-32 Nuts.
- Short 11/32 Socket.
- Small Vice Grips
- 1 / 4" Halyard Line 2 x the stay length + 3 feet.
- Spare A Halyard Line
- 5/16 Control Line 1.5 times the vessel length.
- Fair Leads for the Control Line and Cleat.
- Glue Stick
- 10-to-12-inch Nylon Tie

Preparation for Installation

PREVENT OVERBOARD PARTS - We suggest tethering all loose parts to a line that is secured to the vessel and use a base tarp as a catch - all. (An umbrella works too!)

- Ensure the forestay is in good condition and free of any fixtures.

USER NOTES:

Step 1

Assemble Drum

The Drum comes shipped assembled to show the correct spacer and Insert Pin configuration. Use care and read the following before re-assembling.

- Insert a Nylon Tie to secure the two Drum halves together on the stay.

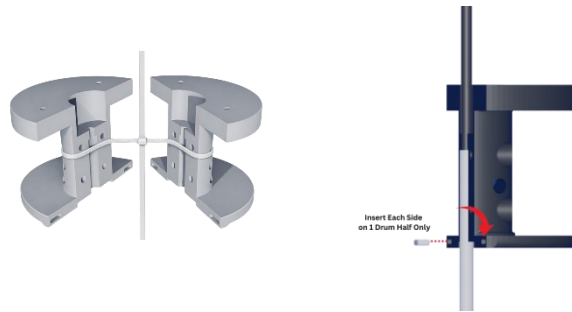

- Connect 4 bolts through the Drum with TWO spacers on the head side of the bolt to prevent rope chafing.

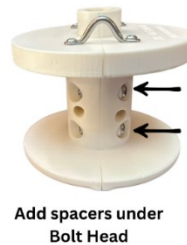

- Insert a Pin on left and right of ONE Lower Drum Disc only. Pins are shipped loose but can be glued in place permanently with a very smear of glue stick.

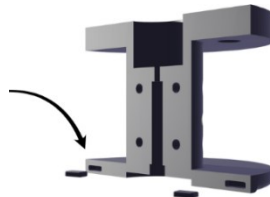

- Install 1 Pad Eye Half on 1 Drum and tighten the nuts with either a socket or the hex tool included. (DO NOT OVERTIGHTEN). The 2nd half of the Pad Eye will be installed after the Foils are completed.
- DO NOT TIGHTEN the Drum but ensure that it fits over the swage and turns by hand.

Step 2

Top Assembly

- Place Top Assembly Marked AFFA (First A) on the Stay and insert the profile marked First Foil B (AFFB) into the self-guided Top Assembly and add insert pin.

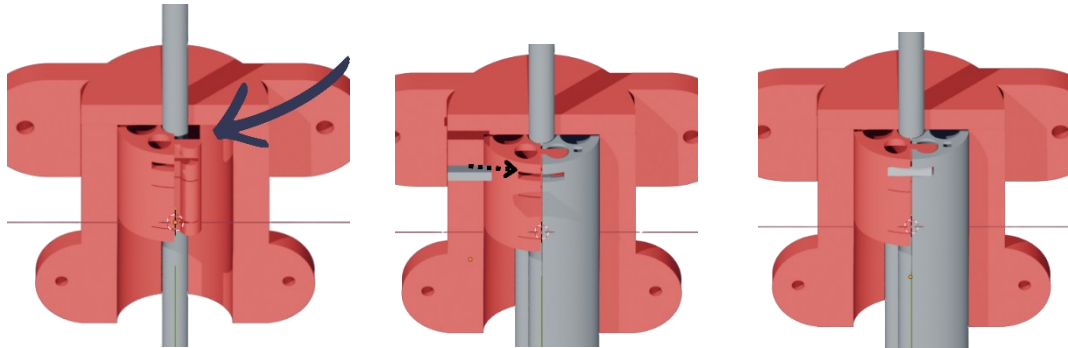

- ADD First Foil A (AFFA,) and Insert Lock Pin.

Attach Pulleys and Bolts to Upper and Lower Flange (DO NOT OVERTIGHTEN) and Add Top Assembly Part B marked AFTPB

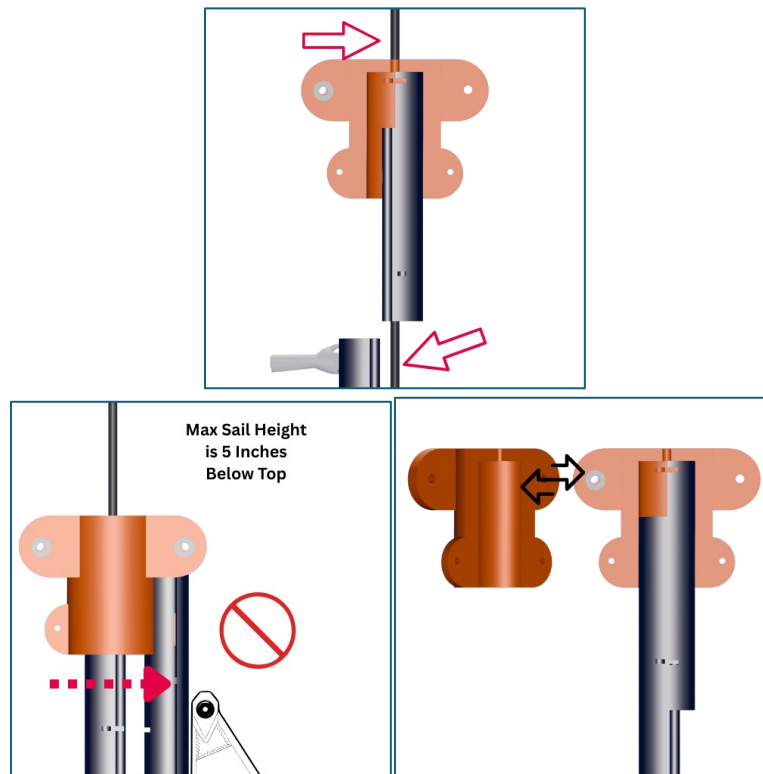

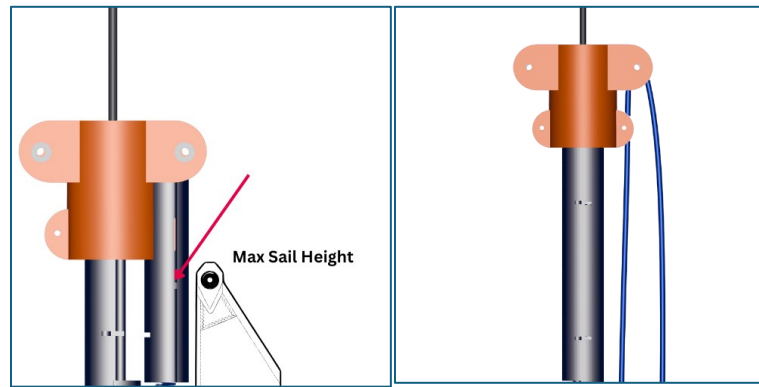

Connect Top A & B & Pulleys

- On the B FOIL loop a ¼ Inch Halyard and secure one bitter end at the deck and allow the other bitter end to pay out from a box, loop or roll.
- You can also secure another Halyard or removable Messenger Line to the deck as a spare line for a pole or spinnaker and to assist with the Foil Installation. Pulling down the bitter end as you add FOILS will ensure that the Foils stay flush to each end.

Step 3

Install Remaining Foils, Luff Feed & Insert in Drum

- Add the remaining A and B Foils, each time raising the system until there are no more B Foils
NOTE: Insert Pins are optional and are there to help support FOIL B.
Always support FOIL B or rest it on the drum to prevent the system from sliding down.



You can also place a pair of vice-grips below FOIL B to temporarily support the foil while you get the next FOIL A in position.

Once the foils are all in position, you will have 1 6-Inch LUFF FEED FOIL to add as the final B FOIL. Check to make sure that the bottom of the LUFF FEED FOIL is in line with the last A FOIL with no over-hang. If there is an overhang, visibly check each foil for gaps between them.

- Add Luff Feed (No Insert Lock Needed) to the B Side Only.

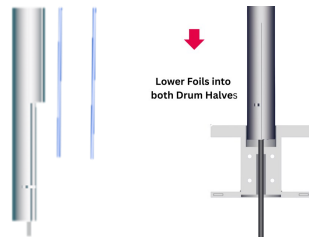

Insert Foils into Drum

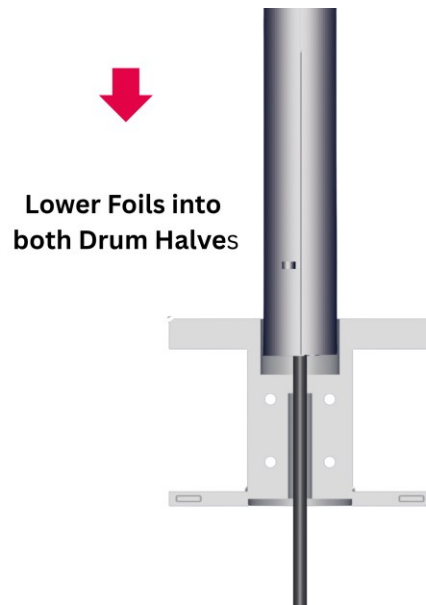

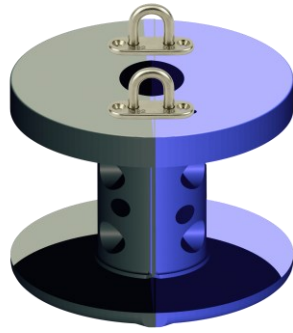

- Snug Bolts but after foils are in but DO NOT OVERTIGHTEN.

Step 4

Final Checks

- Ensure all Drum bolts are snug but not overtightened.
- Confirm the system rotates freely.



Step 5 – Add the Sail & Trim Halyard Line

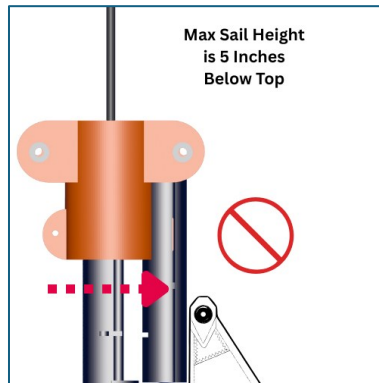

1
Measure line so you will have enough to secure to the Pad Eye,

Attach both Bitter Ends through the Head Sail grommet.

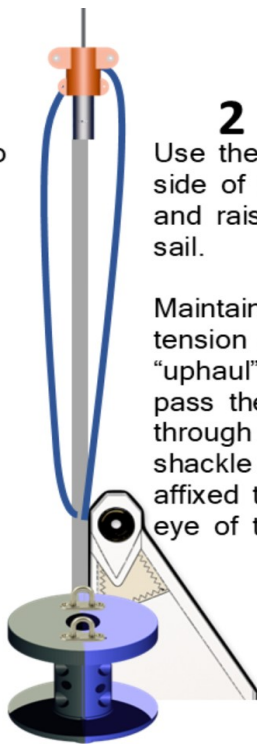

2
Use the “uphaul” side of the line and raise the sail.

Maintain hand tension on the “uphaul” line and pass the loop through a shackle or block affixed to the eye of the drum.



3
With the loop secured, both lines will rest vertically beside foils.

To remove the sail, reverse the process by untying the loop at the drum and using the “downhaul” side of the line

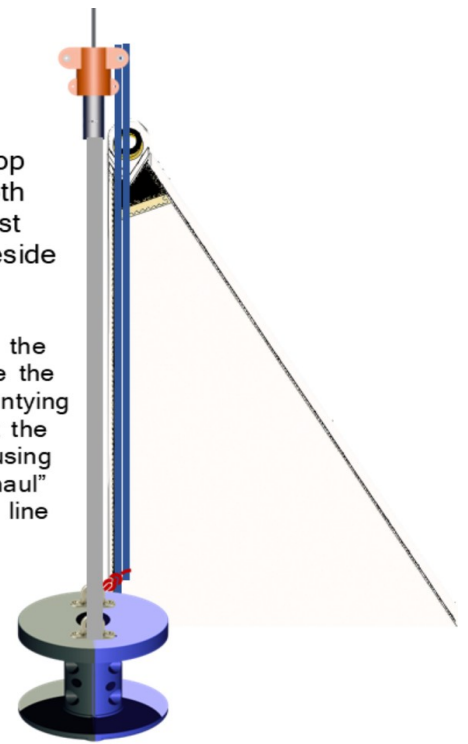

CONTROL LINE – Measure 1.5 times the length of the boat or use Spool.

- Rotate the entire Furler in the direction that you want it to FURL until you have at least 3 wraps of Jib Sheets around the foils.
- Use either drum side to feed the control line through the upper opening and tie off with a figure 8 or equivalent stop knot. You can also flare the bitter end and apply heat. Ensure that the first control line Fair Lead terminates at an angle which allows the drum to freely turn.

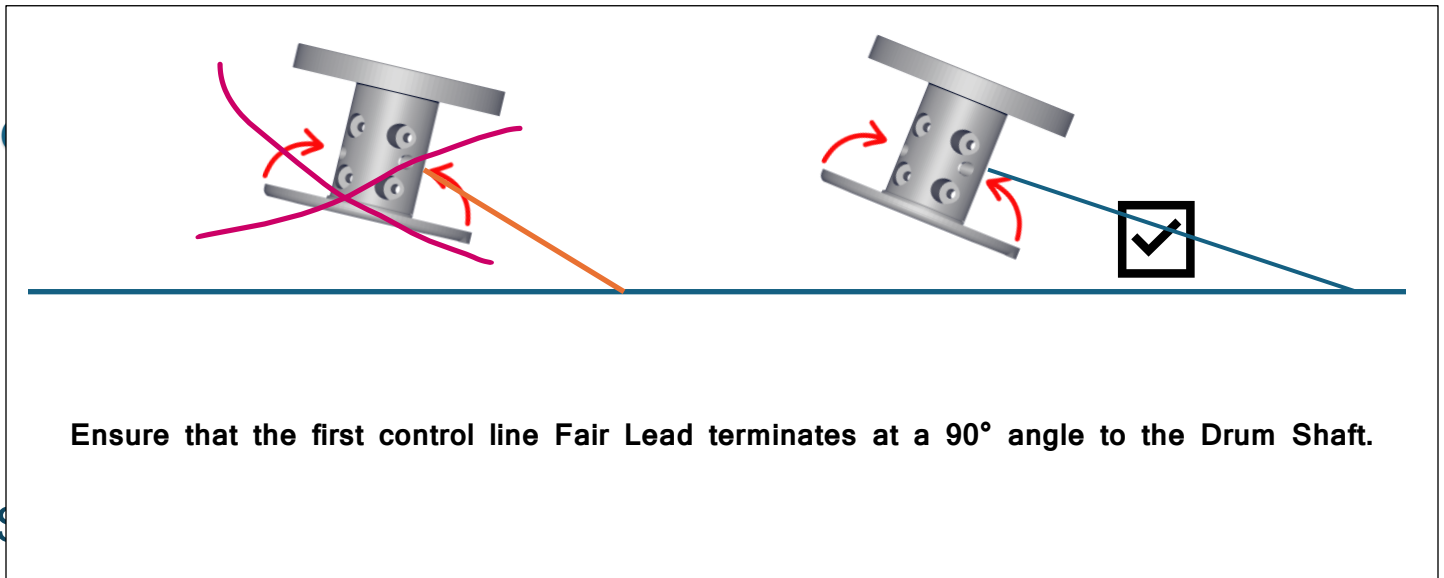

Trial the System

The best time to trial any roller furler is when you can control the direction of wind to on the bow.

This is accomplished by anchoring somewhere safe and installing the sail.

Under safe conditions, pull the appropriate jib sheet outwards, while maintaining a little tension on the Control Line.

The Control Line will start to wrap the Drum. Adjust your Reefing to your liking.

To Reef or Furl the Furler, point the vessel into wind to reduce pressure on the sail, then slowly & simultaneously pull the control line in and pay out the Jib Sheet Lines.

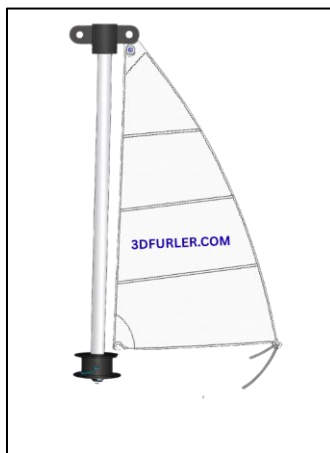

Operating the 3D Furler

Caution: Safe Operation Guidelines

- Always operate the furler in safe conditions. Avoid deploying or reefing the sail in dangerous wind or stormy weather.
- Be aware of other vessels and waterway traffic. Ensure the area is clear before operating the furler or adjusting sails.
- Do not attempt installation or operation in high winds. Wait for calm weather to prevent injury or equipment damage.
 - Keep hands, clothing, and equipment clear of moving parts during operation.
- Regularly inspect all bolts, nuts, and connections for security. Do not overtighten but ensure nothing is loose.
 - If the furler does not operate smoothly, stop and troubleshoot before continuing.
- The 3D Furler is constructed using advanced 3D printing techniques for optimal strength and durability.
- Do not cut, drill, or modify any of the 3D printed components. Altering the parts may compromise their structural integrity and lead to equipment failure or unsafe operation.
 - Do not lubricate with any acetone-based products.
 - If adjustments or replacements are needed, contact 904-600-4105 for support.

Liability Waiver Statement

The 3D Furler and all related components are designed for safe and reliable operation when installed and used according to the instructions provided. 3DFURLER.COM and its affiliates assume no responsibility or liability for any injury, damage, or loss resulting from improper installation, modification, misuse, or operation of this product. Users accept all risks associated with installation and use, including but not limited to risks arising from adverse weather conditions, failure to follow safety guidelines, or unauthorized alterations to any 3D printed parts.

By installing and operating the American Furler, you acknowledge and agree to these terms. If you have any questions or concerns, contact Help@3DFURLER.COM before proceeding.

Here are some tips to give you the best and safest performance possible.

Deployment – Let out the sail and load the drum.

Always deploy with the vessel's bow pointing into the wind. This will reduce the pressure on your sail, sheets and on the crew.

Prepare the appropriate sheet for use and ensure the windward sheet is also free to take up any slack. Reduce Power to Idle.

Prepare the control line (wrap around a winch if possible) and ensure that there is tension on it. The control line is used to CONTROL the SPEED of the Sail as it unfurls.

Deployment should be steady and should not be freewheeled as any excess rope will tangle itself on the drum.

Visually watch the Drum as you unfurl and slow down the speed if you see any misalignment as the Drum is being loaded.

Be aware of wind factors beyond your vessel's safety limits as well as your own skill level.

Reefing

The best time to reef is when you deploy the sail. If the wind forecasts are to increase during your passage, then reefing early is safe and wise. Remember it is less disruptive to let out the control line than to bring it in.

If you do need to reef mid passage, then you will need to steer into wind to reduce pressure and maintain tension on the control line as you pull in.

Remember that every "doubling" of wind speed is "quadrupling" of pressure.

Reefing at night without light in winds will still require a deviation of course.

Furling – Full Stop – Unload the Drum

Point the vessel to wind and if necessary, use the engine power to prevent tacking of the vessel.

Loosen the sail sheets and bring in the control line. Secure the control line.

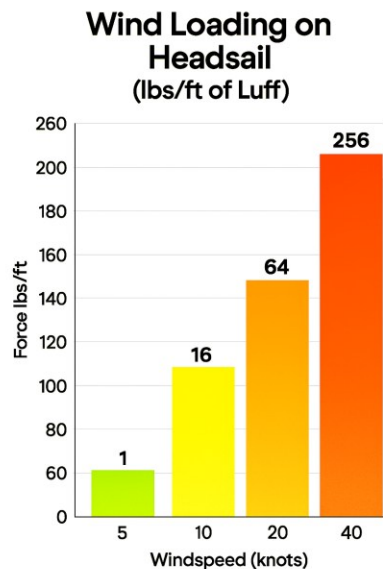

Trouble Shooting

Problem	Possible Cause	Solution
Drum does not turn smoothly	Control line angle.	Reset the 1 st Fair Lead
“”	Incorrect Opening	Re-Feed Control through upper opening.
System not rotating	Top Assembly too high due to faulty measuring of sail.	Remove one set of A & B Foils.
Sail not going to the Top	Incorrectly Sized Sail	Check Measurements
Control Line Fouling over Drum	Over Speed during Deployment	Add more Tension to the Control Line
Hard to Reef in High Winds	Excessive Air Pressure	Steer the Bow into Wind to Alleviate Pressure, Reef and reset Course
Drum is dropping below Swage	Incorrect wire size	Re-confirm wire size and contact help@3dfurler.com
Foils are too tight on the wire	Incorrect wire size	Re-confirm wire size and contact help@3dfurler.com