



3D FURLER INSTALLATION GUIDE

Welcome

This guide walks you through installing the 3D Furler system with clear steps, helpful tips, and easy-to-follow diagrams. Whether you're upgrading or setting up for the first time, it's designed to make the process smooth, safe, and stress-free.

3DFurler
help@3dfurler.com
904-600-4105
Version 8

Contents



.....	2
3D Furler™ Installation Manual	2
Introduction	2
Parts Included	2
Tools and Materials Required	2
Step 1	3
Step 2	3
Top Assembly	3
Step 3	6
Install Remaining Foils & Luff Feed	6
Insert Foils into Drum	7
Step 4	7
Final Checks.....	7
Step 5 – Add the Sail & Trim Halyard Line	7
FURLING LINE – Drum Angle and Fair Leads.....	9
Step 6 – Loading the Sail	10
Operating the 3D Furler	11
Trouble Shooting.....	14



3D Furler™ Installation Manual

By 3DFURLER.COM Email: Help@3DFURLER.COM Tel. 904-600-4105

Introduction

Congratulations on your 3D Furler Purchase. The 3D Furler is designed for long-lasting, trouble-free performance with simple operation.

Parts Included

Top Assembly Parts A & B

Rubber Friction Bar

Standard Foils

2 Luff Foils

Insert Lock Pins – 1 per foil

Pulleys (2)

Drum Halves (2)

4 ¼ - 20 x 1.5 Inch Round Head Stainless Steel Bolts and Nylon Nuts). (DRUM)

2 ¼ - 20 x 3/4 Inch Stainless Steel Bolts and Nylon Nuts for Top Assembly

2 ¼ - 20 x 2 1/2 Inch Stainless Steel Bolts and Nylon Nuts for Top Assembly.

Tools and Materials Required

- Philips Screwdriver to fit ¼ - 20 bolts and 8/32.
- Adjustable Wrench
- Nut Driver or Socket to fit ¼ - 20 Nylon Nuts and #8-32 Nuts.
- Small Vice Grips
- 1 / 4" Halyard Line twice the stay length + 3 feet.
- 5/16 Control Line 1.5 times the vessel length.
- Fair Leads for the Control Line and Cleat.
- 10-to-12-inch Nylon Ties or Carabiner Bungee cords to secure parts while working around water.

Preparation for Installation

PREVENT OVERBOARD PARTS – We suggest tethering all loose parts to a line that is secured to the vessel and using a base tarp as a catch – all. (An umbrella works too!)

If installing the vessel is on the “hard” , lay a tarp down below the bow, so you won’t lose parts if they “jump” overboard.



- Tension the forestay and ensure the rigging is tuned before attempting installation. Installing any roller furler on a loose forestay can result in damage to the furler. Follow the LOOS™ tension guides for tuning.

Step 1

Preparing the Drum

The Drum comes shipped partially assembled to show the correct spacer and Insert Pin configurations. Use care and read the following before re-assembling.

Use Control Line Feeds
to secure both halves
around the stay

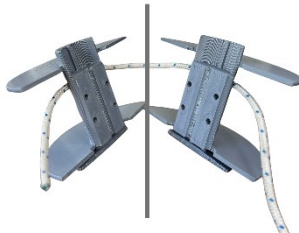

Insert Bolts and Nylon Nuts &
leave loosely fitting



1. Secure the two Drum halves together on the stay to prevent dropping overboard.
2. Connect 4 bolts through the Drum and leave loose letting the drum rest on the swage shoulder. The drum will serve as support for the foils as you install.

Step 2

Top Assembly

1. Secure both Top Halves together around the stay to prevent dropping overboard.

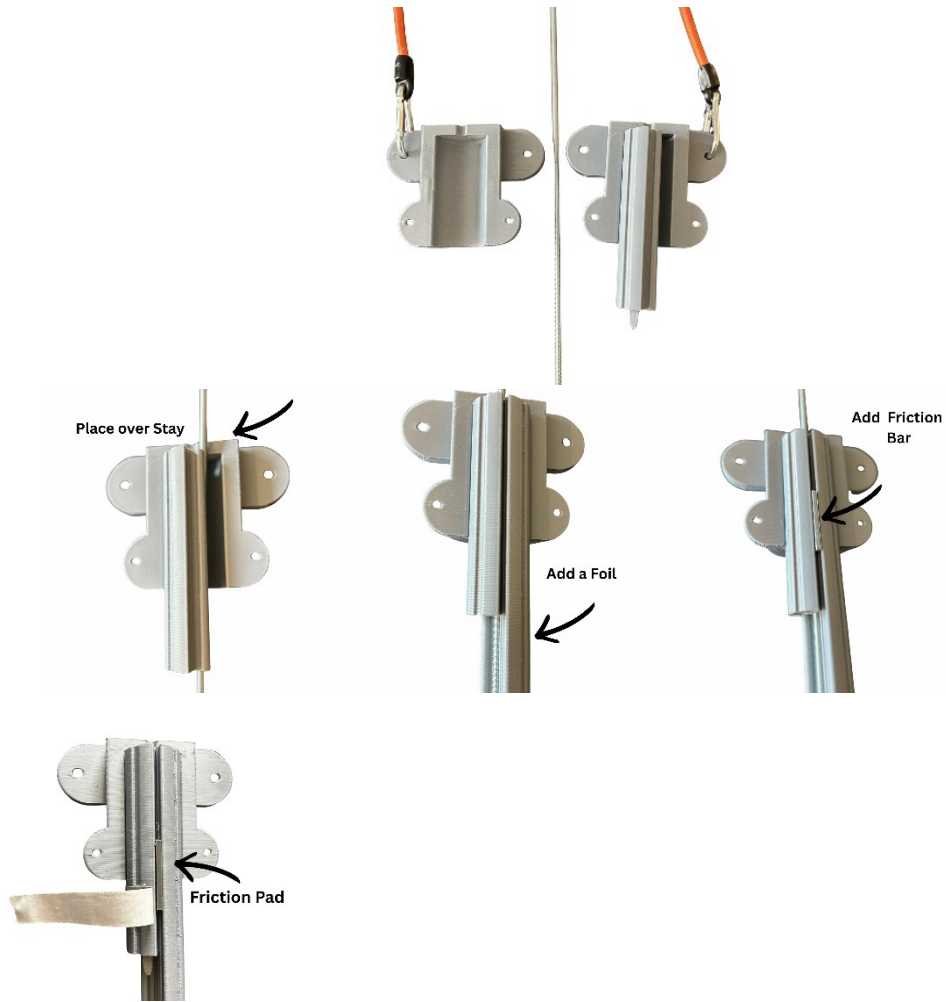

2. Place the Top Assembly on the wire.
3. Add a Foil.
4. Press in the Rubber Friction Pad to hold the Foil from sliding. We also suggest wrapping a piece of Gaff or Sail Tape around for additional security. Note: The Friction Pad and Tape are used to keep the foils from dropping as you add them, once installed they serve no additional purpose and there is no harm leaving them on after the installation.

Press the Rubber Bar into the Foil Gap



Add Sail or Gaff Tape around the two Foils for extra temporary security during installation



Add the short bolts first then add the pulleys

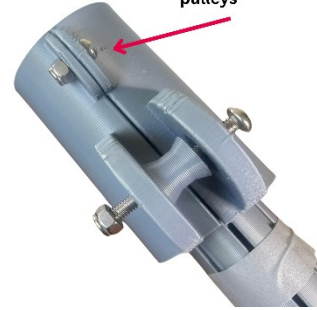

5. Add the Top Cover Plate, Bolts, Pulleys and tighten the nylon nuts to ensure there are at least 3 threads coming out. The bolts and pulleys should be loose to spin.

Tighten but Bolts must Spin

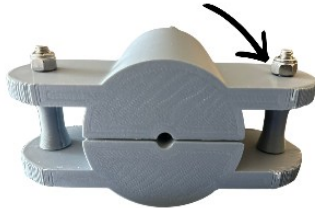

Add Halyard(s) Before Adding Foils

6. Before adding Halyards, determine which side your External Halyard line will go on by referring to the legend below. If you are unsure how many Foils you will be using, then add two temporary lines (one to each side) and replace later with 1/4 Inch Double Braid as needed.

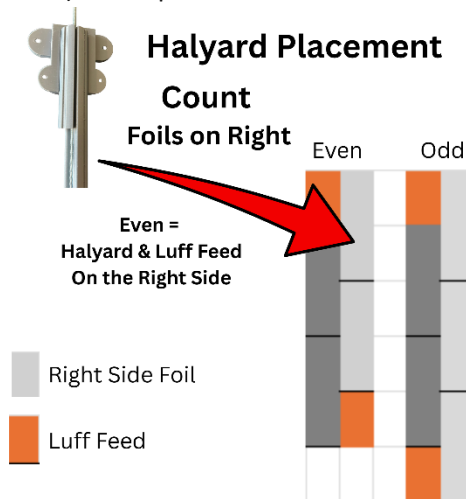

Step 3

Install Remaining Foils & Luff Feed



7. Once the foils are all in position, On systems up to & including 3/16" wires you will have 2 6-Inch LUFF FEED FOILS to add as the final FOIL depending on which side of the system you place the halyard. On larger systems ¼" and higher, you will have 1 Full Size Luff Foil, with the last 6 Inch Foil as a regular.
8. Insert the Temporary Joiner Pins to keep the foil from sliding down.

CAUTION

Joiner Pins are not for unassisted foil support. If you need to take a break, always add the last Short Foil and rest the system on the Drum before letting go of the system.

9. Check to make sure that the Last Foils are even lengths. If there is an overhang, visibly check each foil for gaps between them.

Insert Foils into Drum

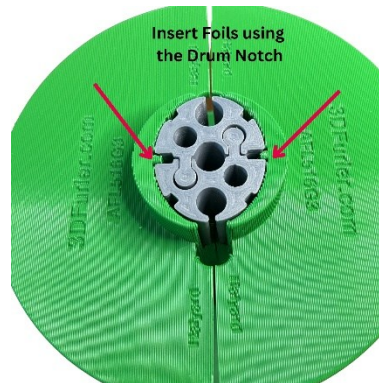

1. Position the foil gap to align with the Drum Notch
2. Tighten the bolts evenly until they just stop and no more 2 ft. lbs.
3. Do a final tightening until the bolts stop. The gap should close in equally between both halves leaving just a slight curvature.

Step 4

Final Checks

1. Ensure all Drum bolts are snug but not overtightened. (max. 2 ft. lbs.)
2. Confirm the system rotates freely.

Step 5 – Add the Sail & Trim Halyard Line

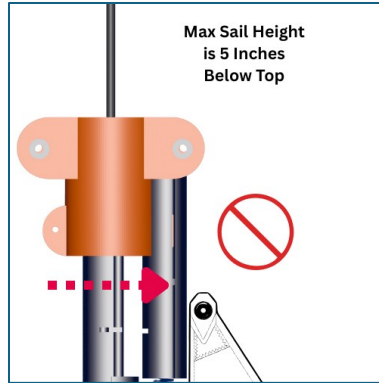

Attaching the Halyard Line & Sail Tack

1. See STEP 6 before proceeding.
2. Feed the sail through the luff feed and start slowly hauling it upwards until you reach the top. DO NOT ATTEMPT to stretch the sail luff or add excessive tension to the line.
3. Place the “uphaul” line that you pulled down to carry the sail up, through the hub channel on the same side of the Drum Top and Bottom.
4. Temporarily secure the line to the Turnbuckle or equally secure place to free your hands and assemble the Clamps as provided.

Under Drum Clamps

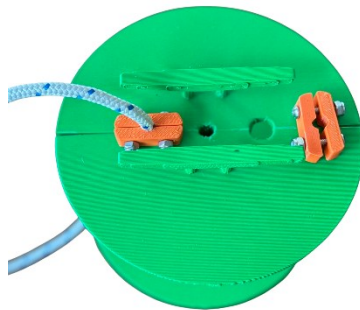

Temporarily Secure Halyard



5. Secure the Halyard by using the Clamps provided so they snug up under the bottom Flange.
6. Remove the temporary halyard tie and trim the excess line to short enough that you can re-tie the two pieces later in order to remove the sail without losing the halyard line.



7. Use the cleat to store the remaining end of the line. DO NOT ATTEMPT to secure the line on the cleat without using the clamps.

FURLING LINE – Drum Angle and Fair Leads



The Drum contains Top and Lower Control Access. Depending on where your Fair Leads are mounted, it will determine which one you use.

The control line must be as close to 90° to the Drum Hub as possible.

Tip: If Top or Lower is not good for your setup, then you can run a small line into the Top and exit at the Lower to form a loop that will center itself.

1. Most vessels use about 1.5 times the vessel length of Furling Line.

5/16" Control Line Capacity on 150 r

Layer	Effective Diameter (mm)	Rotations This Layer	Cumulative Rotations	Rope Length This Layer (ft)	Cumulative Rope Length (ft)
1	60.0	10	10	6.2	6.2
2	75.9	10	20	7.8	14.0
3	91.8	10	30	9.5	23.5
4	107.6	10	30	11.1	34.6
5	123.5	10	40	11.1	47.4
6	139.4	10	50	12.8	47.4
6	139.4	10	60	14.4	61.7
Total Capacity: ≈ 62 feet of 5/16" Rope			60 Total Rotations ≈ 61.7 feet Total		

Feed the Furling Line into the Access Point and exit on the other side of the drum. Tie a knot and secure.

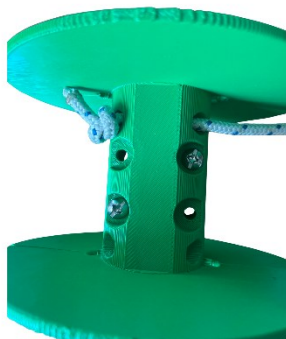

Step 6 – Loading the Sail

The best time to load the sail is when you can control the direction of wind to on the bow. This is best accomplished by anchoring somewhere safe and installing the sail.

Rotate the entire Furler and roll up the sail in the direction that you want it to UNFURL until you have at least 3 wraps of Jib Sheets around the foils.

Under safe conditions, pull the appropriate jib sheet outwards, while maintaining a little tension on the Control Line.

The Control Line will start to feed the Drum. Adjust your Reefing to your liking.

To Reef or Furl the Furler, point the vessel into wind to reduce pressure on the sail, then slowly & simultaneously pull the control line in and pay out the Jib Sheet Lines.

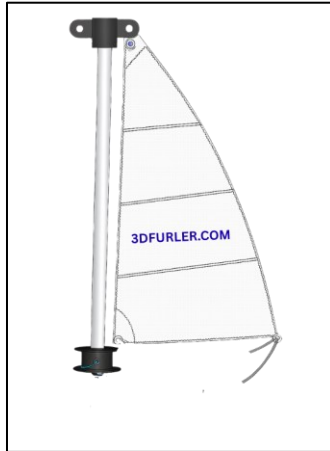

Operating the 3D Furler

Always operate the furler in safe conditions. Avoid deploying or reefing the sail in dangerous wind or stormy weather.

Be aware of other vessels and waterway traffic. Ensure the area is clear before operating the furler or adjusting sails.

Do not attempt installation or operation in high winds. Wait for calm weather to prevent injury or equipment damage.

Keep hands, clothing, and equipment clear of moving parts during operation.

Regularly inspect all bolts, nuts, and connections for security. Do not overtighten but ensure nothing is loose.

If the furler does not operate smoothly, stop and troubleshoot before continuing.

The 3D Furler is constructed using advanced 3D printing techniques for optimal strength and durability.

Do not cut, drill, or modify any of the 3D printed components. Altering the parts may compromise their structural integrity and lead to equipment failure or unsafe operation.

Do not lubricate with any acetone-based products.

If adjustments or replacements are needed, contact 904-600-4105 for support.

Liability Waiver Statement

The 3D Furler and all related components are designed for safe and reliable operation when installed and used according to the instructions provided. 3DFURLER.COM and its affiliates assume no responsibility or liability for any injury, damage, or loss resulting from improper installation, modification, misuse, or operation of this product. Users accept all risks associated with installation and use, including but not limited to risks arising from adverse weather conditions, failure to follow safety guidelines, or unauthorized alterations to any 3D printed parts.

By installing and operating the American Furler, you acknowledge and agree to these terms. If you have any questions or concerns, contact Help@3DFURLER.COM before proceeding.

Tips to give you the best and safest performance possible.

Unfurling –

Always deploy with the vessel's bow pointing into the wind. This will reduce the pressure on your sail, sheets, furler and crew.

Prepare the appropriate jib sheet for use and ensure the windward sheet is also free and take up any slack. Reduce Power to Idle.

Prepare the control line (wrap around a winch if possible) and ensure that there is tension on it. The control line is used to CONTROL the SPEED of the Sail as it unfurls and prevent drum entanglement.

Unfurling should be steady and should not be freewheeled as any excess rope will tangle itself on the drum.

Visually watch the Drum as you unfurl and stop if you see any misalignment as the Drum is being loaded.

Be aware of wind factors beyond your vessel's safety limits as well as your own skill level.

Reefing

The best time to set a reef is when you deploy the sail. If the wind forecasts are to increase during your passage, then reefing early is safe and wise. Remember it is less disruptive to let out the control line than to bring it in.

If you do need to reef mid passage, then you will need to steer into wind to reduce pressure and maintain tension on the control line as you pull in and /or let out the sheets to reduce pressure.

Remember that every “doubling” of wind speed is “quadrupling” of wind pressure.

Reefing at night without light in winds will still require a deviation of course.

Furling – Full Stop Point the vessel to wind and if necessary, use the engine power to prevent tacking of the vessel.

Loosen the sail sheets and bring in the control line. Secure the control line.

Trouble Shooting

Problem	Possible Cause	Solution
Drum does not turn smoothly	Control line angle.	Reset the Fair Leads
Same	Incorrect Opening	Re-Feed Control through different opening.
System not rotating	Top Assembly jamming on the mast.	Remove one set of A & B Foils.
Sail not going to the Top	Incorrectly Sized Sail Halyard Line Crossed	Check Measurements Remove sail and uncross
Control Line Fouling over Drum	Over Speed during Deployment	Add more Tension to the Control Line
Hard to Reef in High Winds	Excessive Air Pressure	Steer into Wind
Drum is dropping below Swage	Incorrect wire size	Re-confirm wire size and contact help@3dfurler.com
Foils are too tight on the wire	Incorrect wire size	Re-confirm wire size and contact help@3dfurler.com